

V200/V210 hybrid

Electronic register for the V200 family of water meters



- easy-to-read LCD
- built-in radio
- external aerial option for pit applications
- low flow capture
- reading integrity
- operational alarms
- tariff capability
- IP68 protection



Combining the best...

Elster is a world-leader in metering technology with a global reputation for innovation and quality. Introducing the V200 hybrid, Elster matches the unsurpassed accuracy and flow range of the V200 family of meters with the latest advances in intelligent metering system capabilities. The V200 hybrid simplifies water supply management at any chosen level.

Take control...

Available with three output options; encoded, pulse or integrated radio, the V200 hybrid is suitable for both internal and below ground installations, with over 10 years of battery life.

Advanced data features include; meter operation monitor, water usage profiling, status alarms and tariffing.

Meter display and output data will always be consistent

Display and Data Set

The display spends most of its time in the "Normal" mode.

Once every minute it switches to the "Alarm" mode for 3 seconds, an error or alarm exists.

In "Tariff" mode the secondary tariff volume replaces the sub-units.

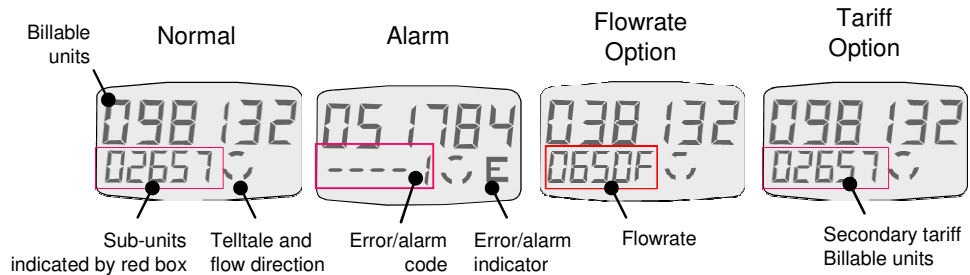

This table lists the complete data set.

Items in the grey area are not editable by the utility, as they are either factory settings or are considered to influence the basic metrology of the meter.

This data set has not been fixed and some features may be removed in the final product, dependent on customer consultation.

	Identification, Audit	Metrology	Alarms	Basic Data logging
Access and set by manufacturing only	1. Set s/w version	10. Set units	15. Reverse flow 16. Leak 17. Burst 18. Battery low 19. Zero Flow All alarms are time-stamped	21. Pulse O/P setup
	2. Set factory password	11. Set calibration factors		22. Feature enable/disable
	3. Set meter serial number	12. Set test mode		23. 24 meter readings at intervals
	4. Set register ident.			24. Peak flow during last calendar year and monitoring period
	5. Set date of manufacture			25. Set monitoring period
	6. Set meter size and type			26. Up to 4 daily cumulative flows
Access by customer and manufacturing	7. Set customer password	13. Get Current meter reading		27. Up to 7 flow band cumulative flows (during monitoring period)
	8. Set date of install	14. Current flow rate		28. Tariff modes
	9. Customer reference number			29. Time with no flow
				30. RTC adjustment
				31. Reverse flow (last occurrence)
				32. Overspeed logging
				33. Count of radio transmissions



Flow Performance to Directive 2004/22/EC, EN14154, OIML R49 and ISO4064

		V210 V200	V210 V200	V210 V200
Nominal Diameter DN	mm	15	20	25
Permanent Flow Q3	m ³ /h	2.5	4.0	6.3
Flowrange (R) Q3/Q1		400	400	160
Minimum Flow Q1	l/h	6.25	10	39.4
Transitional Flow Q2	l/h	10	16	63.0
Overload Flow Q4	m ³ /h	3.125	5	7.875
Starting Flow (approx)	l/h	2	2	3

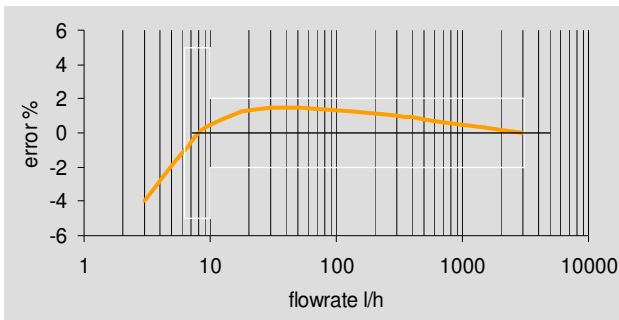
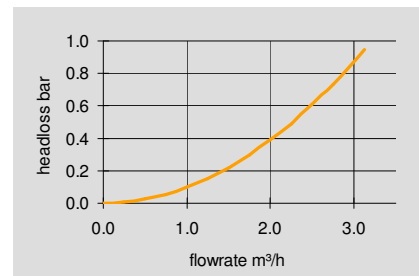

Typical accuracy with no curve shaping

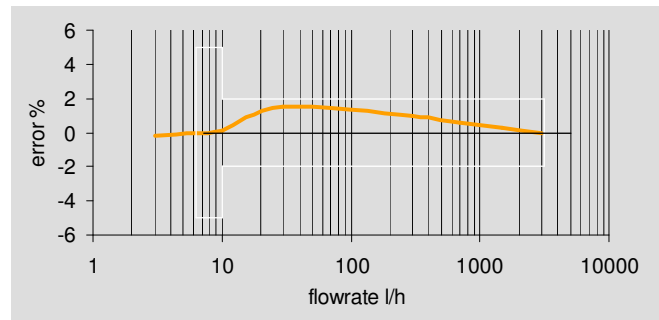

Typical accuracy with curve shaping towards zero error below Q₂.

Technical Characteristics

		V210	V210	V210	V200	V200	V200
Nominal Diameter DN	mm	15	20	25	15	20	25
Thread Size	in	G11/2"A	G11/2"A	G2"A	G3/4"A	G1"A	G11/4"A
Diameter A	mm	94	94	130.5	94	94	120
Height B	mm	140	150	156	127	125	133
Height with lid open C	mm	207	217	223	194.0	192	200
Length D	mm	n/a	n/a	n/a	110, 115 134, 165	165, 190	199, 260
Install Length E	mm	n/a	n/a	n/a	195, 200 228, 250	263, 288	311, 370
Weight	kg	0.92	1.04	2	0.95	1.2, 1.26	2.3, 2.6

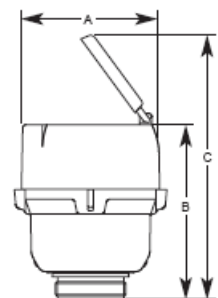

Operational Data (all meters)

Indicating Range	m ³	999 999
Verification Scale Interval	l	0.01
Max. Water Temperature MAT	°C	30
Max. Water Pressure MAP	bar	16
Max. Pressure Loss at Q3	bar	0.63

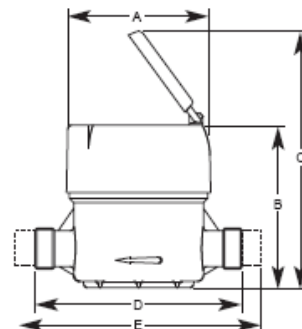

The Company's policy is one of continuous improvement and the right is reserved to modify the specifications without notice.

Pressure Equipments Directive 97/23/EC

This product is applicable to networks for the supply, distribution and discharge of cold potable water and associated equipment and is therefore exempt